

This Wireless PIR (passive infrared) Detector is in-door wireless passive infrared intrusion detector. When a zone is intruded, the detector will output alarm signal via wireless module to upload to wireless alarm host, thus alarm is generated. Available model: ARD1231-W

Before Use

1. Do not touch surface of the detector and the lens, so as not to affect the sensitivity of the detector. If you need to clean the detector and the lens, please turn off the power and use a soft cloth dipping some water to do so.
2. Avoid using the device in an environment of large temperature change, otherwise it will affect the performance of the product.
3. This product can reduce accidents, however there is no guarantee. For your safety, in addition to proper use of the products, but also be vigilant in daily life,.

Product Illustration

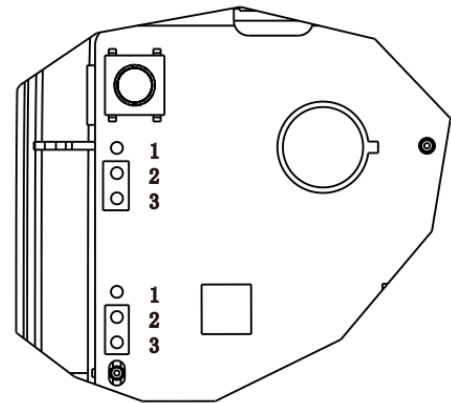
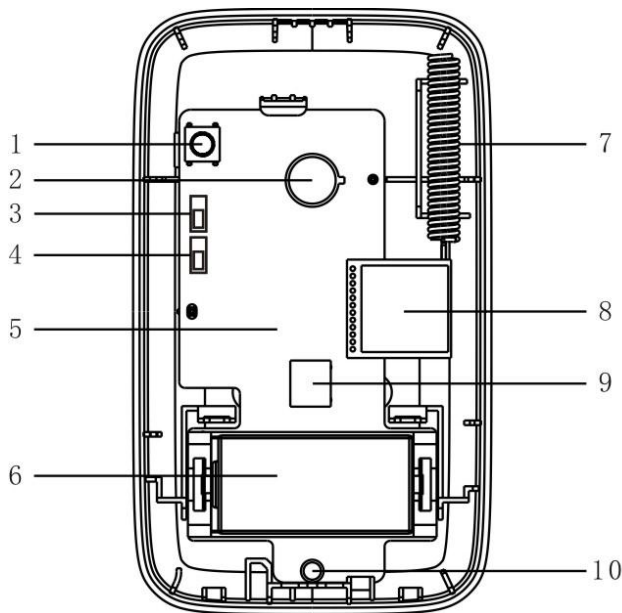

1	Case vandal-proof switch
2	Pyroelectric infrared detector
3	Sensitivity adjustment plunger pin
4	LED plunger pin
5	Motherboard PCB
6	Lithium battery
7	Antenna
8	Wireless module
9	Wall vandal-proof switch
10	LED

Features

- Dual element digital detector, improving accuracy of detection
- One-step detection technology, (sensitivity) adjustable
- Digital anti-interference technology, Anti-visible light $\geq 6500\text{LUX}$
- Digital temperature compensation technology
- Detection distance: 12m, detection angle: 90°
- Standard bracket, support wall mount and corner mount
- Case vandal-proof and wall vandal-proof
- Communication frequency 433MHz, distance 1km(open space)
- Low consumption design, built-in battery life up to 3 years

Range of Detection

Detection range of the detector is shown in Figure 1- 1. Horizontal angle of detection is 90° .

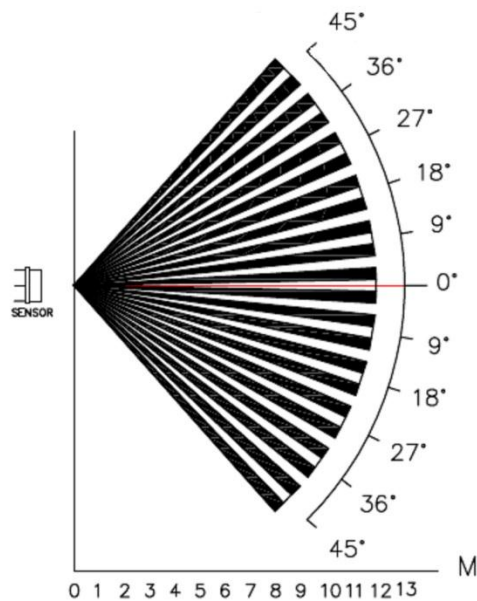

Figure 1- 1

Range of detector is shown in Figure 1- 2. Detection distance is 12m, and the closest distance is 1m.

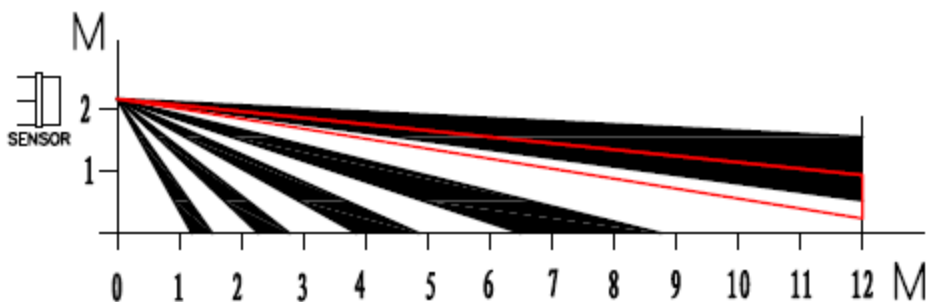

Figure 1- 2

Product Installation

Warning:

- Installation and debugging must be executed by professional staff. If you encounter device failure, please do not open and repair the device, you shall contact its after-sales department.
- Avoid installation under direct sunlight.
- Avoid installation in environment of rapid change in wind speed.
- Avoid installation in places where the temperature is too high.
- Avoid installation in places with obstruction in the detection range of the device.
- Avoid installation in places with a large amount of metal objects.

Steps of installation:

Step 1. Take down installation bracket at the bottom of detector, see Figure 3- 1.

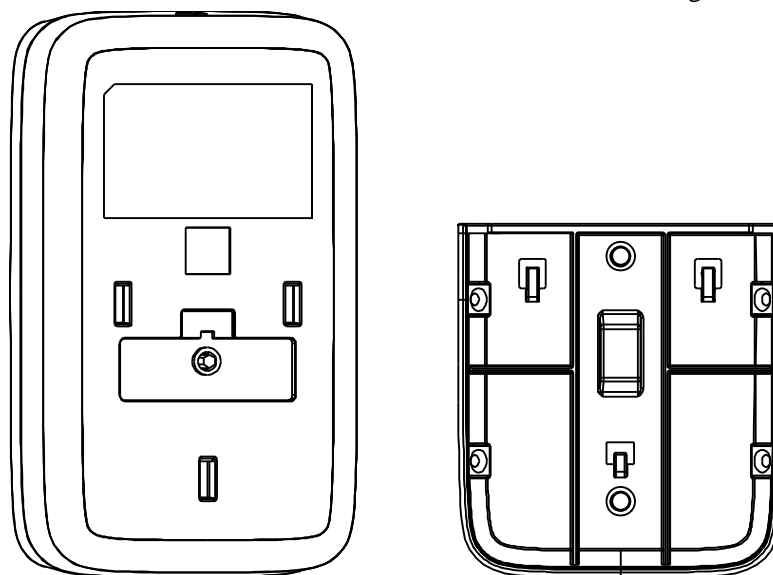

Figure 3- 1

Step 2. Dig through the wiring hole and fixing hole on installation bracket (for wall mount or corner mount).

Step 3. For wall mount, installation bracket bottom is parallel to the wall. Fix it on wall with screw via the hole on installation bracket, and hang device on hanger on installation bracket. See Figure 3- 2.

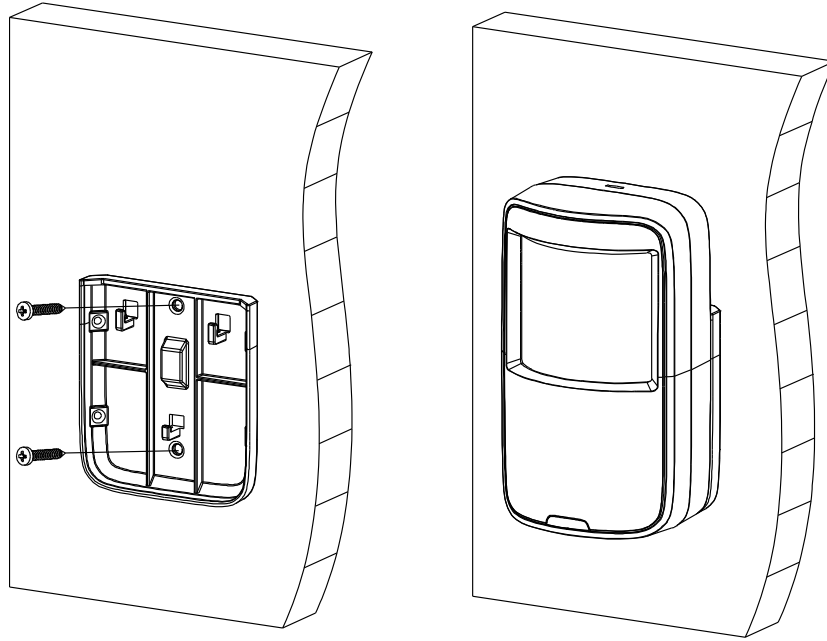

Figure 3-2

Step 4. For corner mount, form a triangle with installation bracket and two walls. Fix it on wall with screw via the hole on installation bracket, and hang device on hanger on installation bracket. See Figure 3-3.

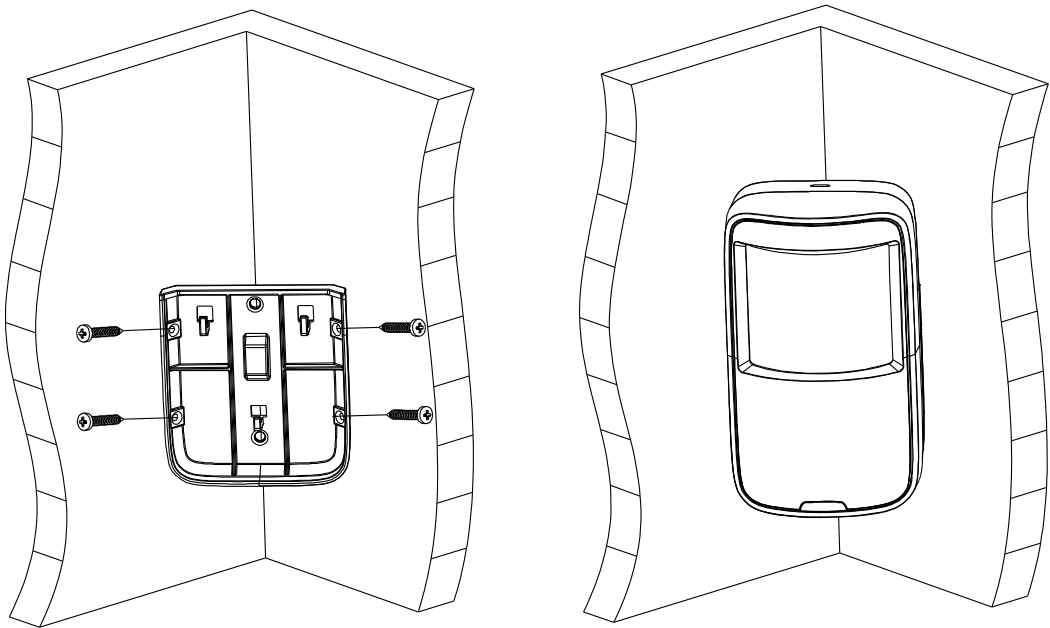

Figure 3-3

Product Usage

1. Network

Before you can normally use wireless PIR detector, you must set network settings.

Two ways to set:

- Via wireless alarm programming keyboard
Under this mode, you enable matching mode at keyboard, and power up the detector. When power indicator is ON, dial vandal-proof switch and indicator is flashing. Wait about 10s, if the indicator is OFF, the matching is successful. If the indicator flashes for three times, the matching is failed. You shall follow these steps and try again.
- Via setting MAC address
Under this mode, you set detector MAC to the MAC address list of wireless alarm host via keyboard and power up the detector. Wait about 40s, if indicator is OFF, the matching is successful.

Note:

If the detector has been matched to other alarm host, you cancel previous matching by quickly dialing vandal-proof switch. (5 times within 1s)

2. LED Setup

You can set LED plunger pin to control LED indicator, while the ON/OFF of indicator represent certain instructions.

You can set two plans at the plunger pin: 1&2 and 2&3, select 1&2 as LED OFF, select 2&3 as LED ON, default setup is LED ON.

Note:

This operation does not influence normal operation of detector.

3. Pulse Count Setup

You can set P.COUNT plunger pin (as pulse count plunger pin) according to product usage environment or distance requirement for sensor.

You can set two levels for position of plunger pin: 1&2 and 2&3; select 1&2 (1P) as level 1 pulse; select 2&3 (2P) as level 2 pulse. Default setup is 1P. 1P sensor sensitivity is high while 2P sensor sensitivity is low.

4. Installation Test

You can test working status of detector:

Within detection range of the detector, walk at the rate of 1m/s to test, red indicator keeps ON for 2s, which means infrared is triggered, and detector enters alarm status. It outputs alarm signal, and red indicator is ON.

Appendix 1: Technical Specifications

Parameter	Note
Detection Method	Dual element passive infrared
Detection Range	12m, 90°, 22 zones
Alarm Prompt	Red LED, may set off
Sensitivity	Two level (jumper cap)
Carrier Frequency	433MHz
Transmitting Power	10dBm
Transmission Distance	1200m(open space/no interference)
Anti-pet	≤18Kg
Anti-visible light	6500LUX
Vandal-proof	Support case vandal proof and wall vandal-proof.
Installation Height	2.2-2.5m
Installation Method	Wall mount, corner mount, and bracket mount.
Dimensions	105*62*41.3mm (L*W*T)
Weight	0.2kg
Temperature	-10℃~50℃
Humidity	< 95%