

Panasonic[®]

Operating Instructions

Wall Mount Bracket

Model No. **WV-Q118B**

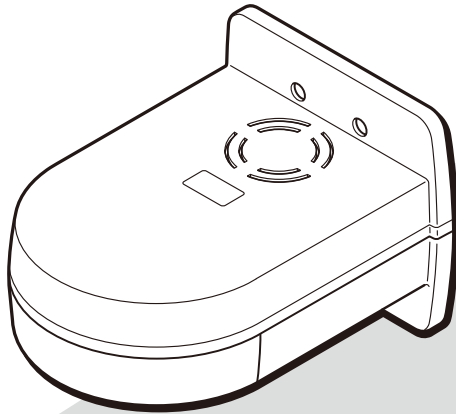

Before attempting to connect or operate this product,
please read these instructions carefully and save this manual for future use.

The model number is abbreviated in some descriptions in this manual.

Contents

- Features..... 3
- Precautions 3
- Precautions for installation 4
- Places of installation..... 5
- Installation 6
- Specifications 13
- Standard accessories..... 13

Features

This bracket is designed to be mounted on a wall.

A combination camera will be installed after attaching this wall bracket to a concrete or other sturdy wall.

Precautions

Refer installation work to the dealer.

Installation work requires technique and experiences. Failure to observe this may cause fire, electric shock, injury, or damage to the product.

Be sure to consult the dealer.

Avoid installing this bracket in the locations where salt damage occurs or corrosive gas is produced.

Otherwise, the mounting portions will deteriorate and accidents such as a fall of this product may occur.

Do not install other than the specific cameras.

Failure to observe this may cause a drop resulting in injury or accidents.

The screws and bolts must be tightened with the specified torque.

Loosening of mounting screws or bolts may cause a fall of the product resulting in injury or accidents.

Do not use this bracket except with suitable cameras.

Failure to observe this may cause a drop resulting in injury.

Check the mounting state of the decorative cases (1) and (2).

Ensure that the decorative cases (1) and (2) are securely mounted to prevent the camera from dropping.

Examine the strength of the mounting point.

If the strength of the mounting point is not sufficient, injury or accidents due to camera dropping may occur.

Reinforce the mounting point to the appropriate level before mounting.

Do not rub the edges of metal parts with your hand.

Strong rubbing may cause injury.

Periodic inspections shall be conducted.

Rust on the metal parts or screws may cause a fall of the product resulting in injury or accidents.

Consult the dealer for the inspections.

Precautions for installation

- Make sure that the installation area is strong enough to hold the total weight of the camera assembly (approx. 3.8 kg {8.4 lbs}) before installation.
- Be sure to use the camera fixing screws (supplied with the camera) to secure the camera body and this bracket, and ensure there is no backlash.
- Screws for mounting this bracket are not supplied.
Prepare them according to the material and strength of the area where the product is to be installed.
 - Required screws: M4 (4 pcs.)
 - The minimum required pull-out capacity of a single screw or anchor bolt is 196 N {44 lbf} or more.
- Do not use this bracket except with suitable cameras.
- The installation should comply with local electrical code.
- Do not place this product in the following places:
 - Locations where it may get wet from rain or water splash
 - Locations where a chemical agent is used such as a swimming pool
 - Locations subject to humidity, dust, steam and oil smoke
 - Locations where a radiation, an X-ray, a strong radio wave or a strong magnetic field is generated
 - Locations where corrosive gas is produced, locations where it may be damaged by briny air such as seashores
 - Locations where the temperature is not within $-10\text{ }^{\circ}\text{C}$ to $+50\text{ }^{\circ}\text{C}$ { 14°F to 122°F }
 - Locations subject to vibrations (This product is not designed for on-vehicle use.)
- Locations subject to condensation as the result of severe changes in temperature (In case of installing the camera in such locations, the dome cover may become foggy or condensation may be caused on the cover.)

Places of installation

There are various ways of installing the camera as shown below.

● Wall box

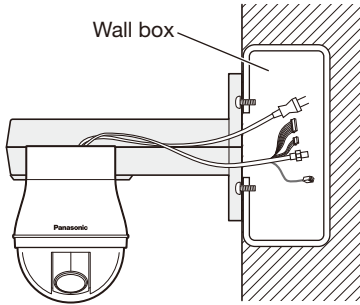

● Wood siding board

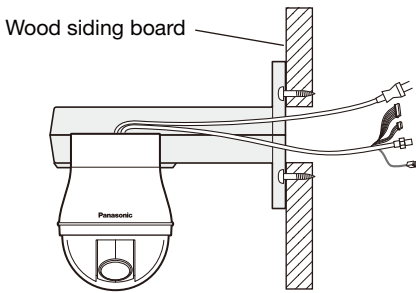

● Concrete

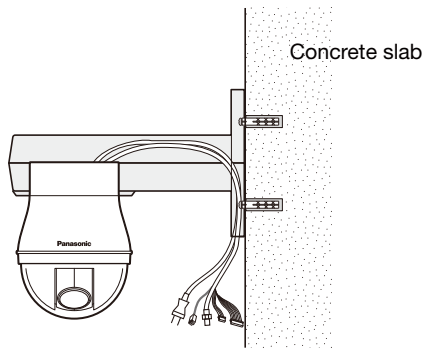
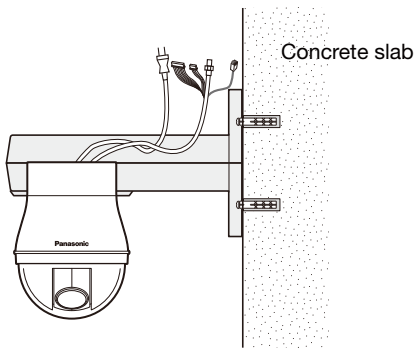

Installation

Be sure to read "Precautions" and "Precautions for installation" before installation. Read the operating instructions for the camera to be installed as well.

For cameras to be installed using the camera mounting base

Step 1

Put the template (accessory) to the wall, and mark the positions of the holes through which screws and cables pass.

If cables are routed inside the wall, bore a hole through the wall.

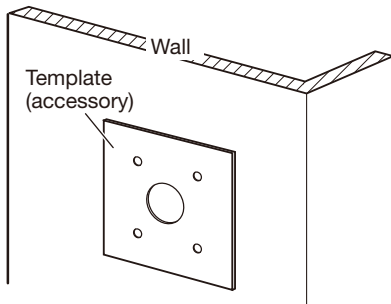

Step 2

Wrap the camera cables with the protection cover (accessory).

Wrap the point of the cables where the cutting part of the camera die-cast case comes.

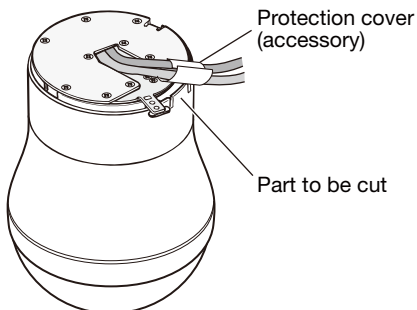

Step 3

Remove the mounting screw, and remove the camera mounting base from the camera body. Be careful not to lose the mounting screw.

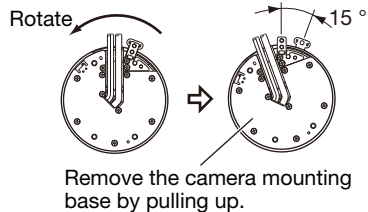
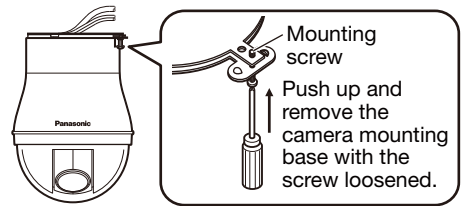

Step 4

Cut the die-cast case of the camera.

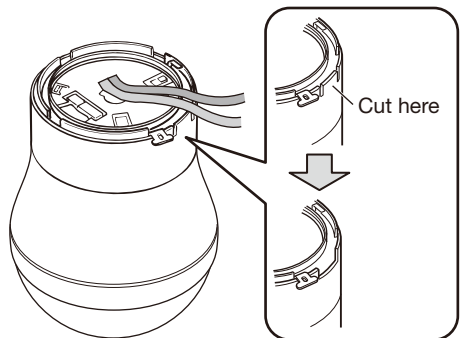

Step 5

Remove the decorative cases in the order of (1) and (2).

The decorative cases can be removed by pulling down the covers while pressing the arrow marks (1 point for the case (1) and 4 points for the case (2)).

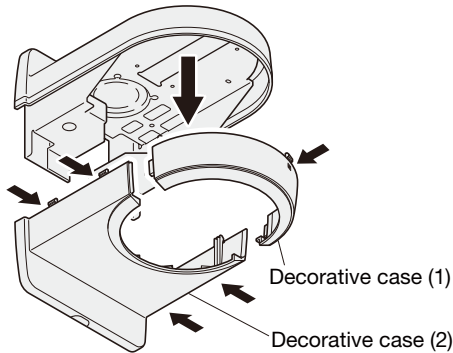

Step 6

Fix the camera mounting base to the top case, and run the cables.

Mount the camera mounting base with the supplied screws (M4-L8) in the consideration of the base direction as shown in the drawing below.

Recommended tightening torque:

1.56 N·m {1.16 lbf·ft}

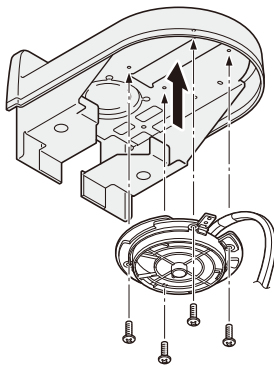

Step 7

Route the cables outward, and secure them with the side clamp.

Route the cables along the top case inside face and secure them with the clamp to prevent the cables from interfering at case mounting or camera mounting.

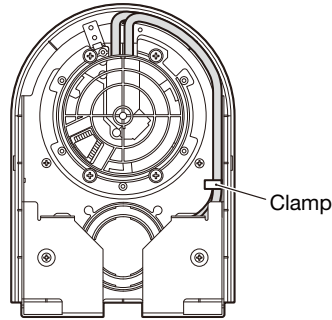

Step 8

Attach the top case to the wall and run the cables.

Attach it with four screws.

Screws are not provided. Prepare them in accordance with the camera installation position.

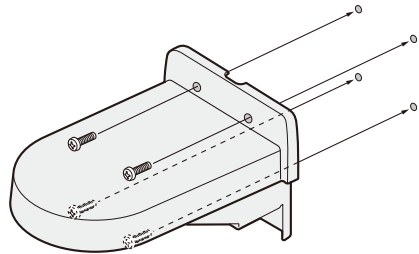

Step 9

Attach the decorative case (2).
Remain the decorative frame (refer to step 10 on page 11) attached to the decorative case (2).
Ensure the decorative frame and the decorative case (2) are steadily fit with each other.

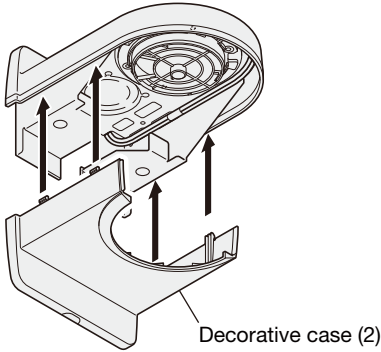

Step 10

Attach the safety wire locked on the camera to the camera mounting base.
Ensure that the top ring of the safety wire is steadily engaged with the hook of the camera mounting base.

*** The bracket is not shown in the illustration below.**

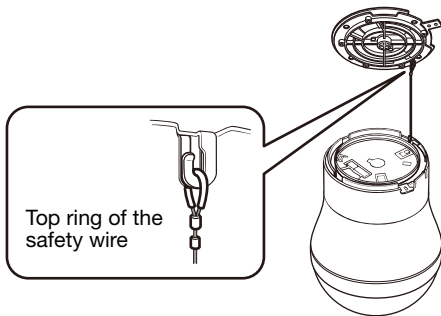

Step 11

Mount the camera on the camera mounting base, and secure them with mounting screw.
Ensure there is no backlash.
Recommended tightening torque:
0.68 N·m {0.51 lbf·ft}

*** The bracket is not shown in the illustration below.**

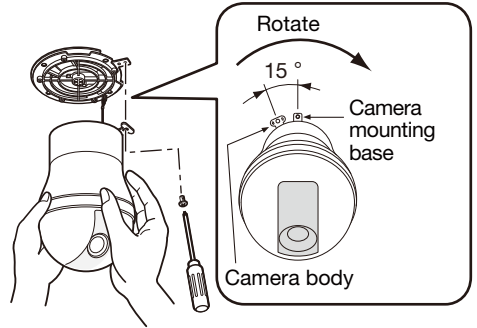

Step 12

After fitting both ends of the decorative case (1) into the decorative case (2), attach the central part.
Ensure the decorative cases (1) and (2) are steadily fit with each other.

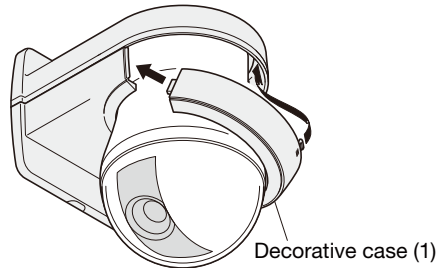

For cameras to be installed using the camera mount bracket

Step 1

Put the template (accessory) to the wall, and mark the positions of the holes through which screws and cables pass.

If cables are routed inside the wall, bore a hole through the wall.

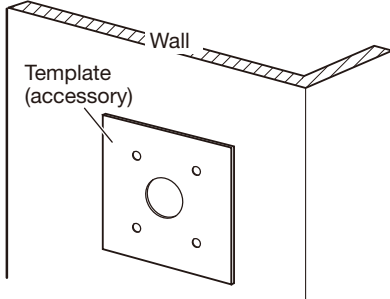

Step 2

Remove the decorative cases in the order of (1) and (2).

The decorative cases can be removed by pulling down the covers while pressing the arrow marks (1 point for the case (1) and 4 points for the case (2)).

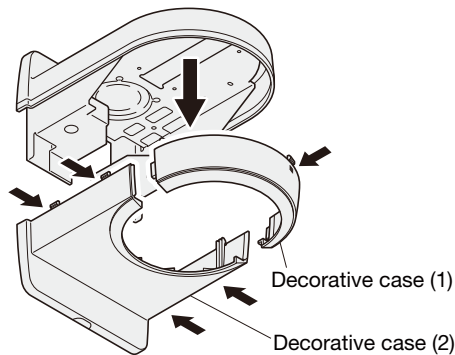

Step 3

Attach the camera mount bracket supplied with the camera to the top case.

Mount the camera mount bracket with the supplied screws (M4-L4) in the consideration of the bracket direction as shown in the drawing below.

Important:

- Do not use the supplied long screws (M4-L8). They may damage the top case.

Recommended tightening torque:

1.56 N·m {1.16 lbf·ft}

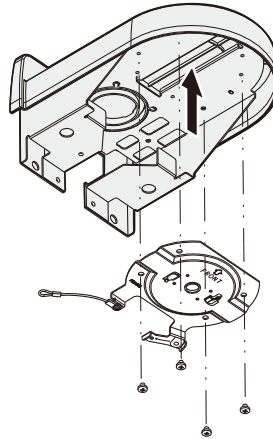

Step 4

Attach the top case to the wall and run the cables.

Attach it with four screws. Screws are not provided. Prepare them in accordance with the camera installation position.

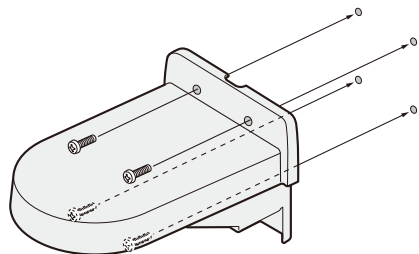

Step 5

Attach the safety wire locked on the camera mount bracket to the camera body. Ensure that the safety wire is steadily engaged with the hook of the camera body.

*** The bracket is not shown in the illustration at below.**

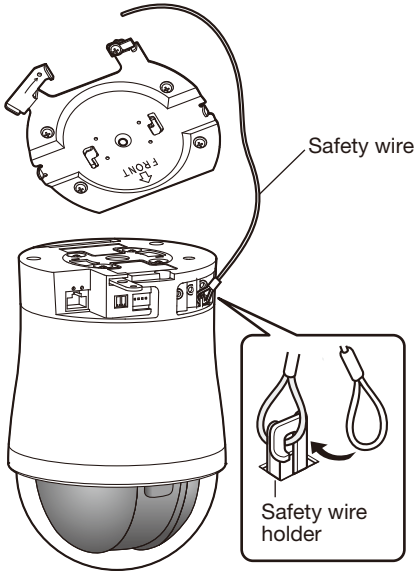

Step 6

Connect the cables to the external I/O terminals, microphone/line connector, audio output connector, and monitor output connector. Refer to the operating instructions of the camera for descriptions of connections. Hold the camera body securely at connections.

Step 7

Connect the cables to the network terminal and 12 V DC power supply terminal. Refer to the operating instructions of the camera body for descriptions of connections.

Step 8

Mount the camera body onto the camera mount bracket. Align the lock plate with the guide of the camera mount bracket, engage the bracket with the camera body while aligning the center of the bracket with the center of the camera, and rotate the camera body clockwise while pressing the camera to the camera mount bracket.

*** The bracket is not shown in the illustration at below.**

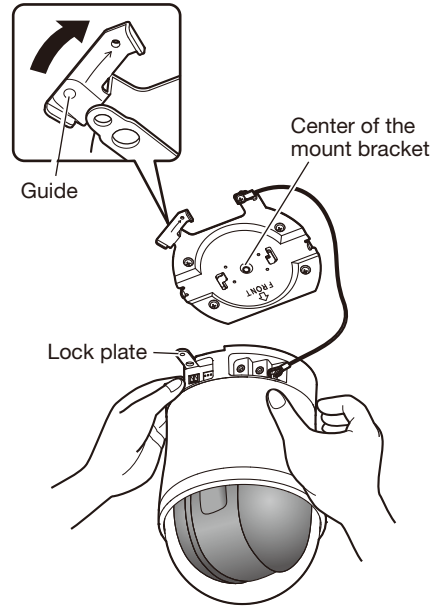

Step 9

Secure the camera mount bracket to the camera with 1 piece of the camera fixing screw (M3, supplied with the camera).
Recommended tightening torque:
0.68 N·m {0.51 lbf·ft}

* The bracket is not shown in the illustration at below.

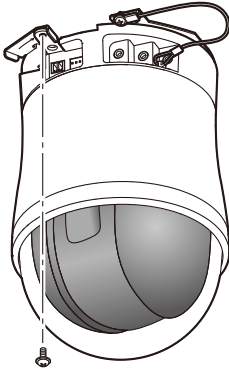

Camera fixing screw
(M3, supplied with the camera)

Step 10

Remove the decorative frame from the decorative case.
Rotation of the decorative frame in the arrow direction allows the tab to be disengaged and the decorative frame to be removed.

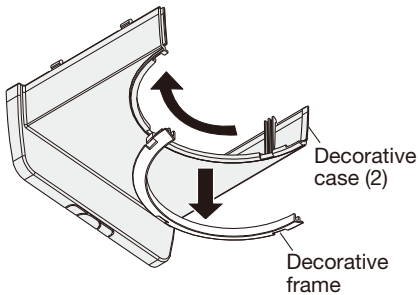

Step 11

Attach the decorative case (2).
Ensure the decorative case (2) and the camera mount bracket are steadily fit with each other.

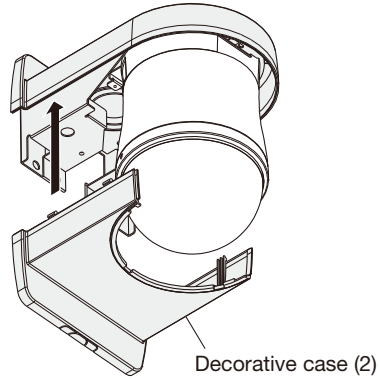

Step 12

Attach the decorative frame to the decorative case.
Align the tabs of the decorative frame with the grooves (3 points) of the decorative case, and rotate the decorative frame in the arrow direction.

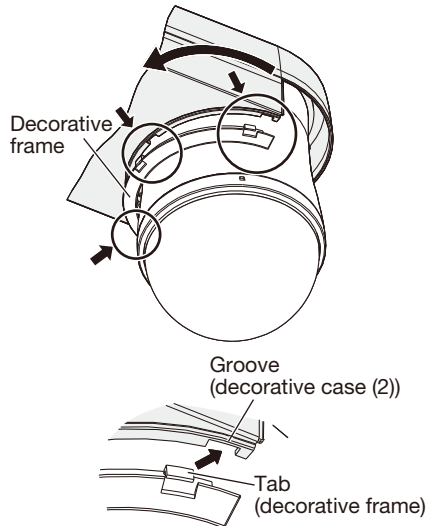

Step 13

Attach the decorative case (1).

After fitting both ends of the decorative case (1) into the decorative case (2), attach the central part.

Ensure the decorative cases (1) and (2) are steadily fit with each other.

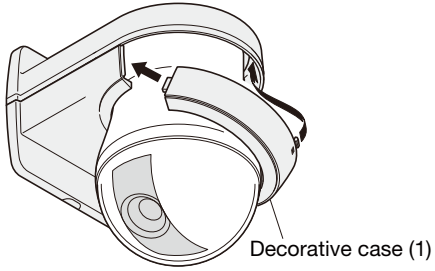

Specifications

| | |
|--------------------------------|---|
| Ambient operating temperature: | -10 °C to +50 °C {14°F to 122°F} |
| Dimensions: | 165 mm (W) x 140 mm (H) x 217.5 mm (D) {6-1/2 inches (W) x 5-1/2 inches (H) x 8-9/16 inches (D)} |
| Mass: | Approx. 650 g {1.43 lbs} |
| Finish: | ABS resin, silver metallic painting |

Standard accessories

| | |
|---|--------------------------------|
| Screw (M4xL8) | 4 pcs. |
| | (For the camera mounting base) |
| Screw (M4xL4) | 4 pcs. |
| | (For the camera mount bracket) |
| Template..... | 1 pc. |
| Protection cover | 1 pc. |
| Operating Instructions (this document)..... | 1 pc. |

For U.S. and Canada:

**Panasonic System Communications
Company of North America,
Unit of Panasonic Corporation
of North America**

www.panasonic.com/business/
For customer support, call 1.800.528.6747
Three Panasonic Way, Secaucus,
New Jersey 07094 U.S.A.

Panasonic Canada Inc.

5770 Ambler Drive, Mississauga,
Ontario, L4W 2T3 Canada
(905)624-5010
www.panasonic.ca

For Europe and other countries:

Panasonic Corporation

<http://panasonic.net>

Importer's name and address to follow EU rules:

Panasonic Testing Centre
Panasonic Marketing Europe GmbH
Winsbergring 15, 22525 Hamburg, Germany