

# AE-301 10 Liter Tank with Pump Installation Guide

Corresponding ordering part number: 900043600G

Rev. 1.3

## UNPACKING:

Unpack carefully. Electronic components can be damaged if improperly handled or dropped. If an item appears damaged in shipment, place it properly in its carton and notify the shipper.



## IMPORTANT!:

1. Read and follow Instructions: All operating and user instructions should be read and followed before the unit is to be operated.
2. Electrical Connections: Only a qualified electrician is allowed to make electrical connections.

## I Introduction

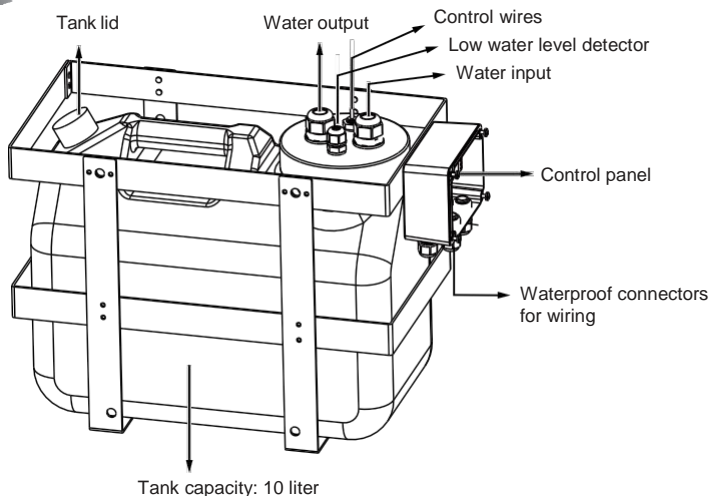

## IMPORTANT:

- Disconnect devices: A readily accessible disconnect device in the building installation wiring should be incorporated.
- The total weight of the tank pump is 12kgs. You need to rigid wall surface to support the weight or you can pole-mount the unit.

## II Components

The installation procedure include the following components:

- |                                           |
|-------------------------------------------|
| 1. A speed dome with wiper, e.g., SD9366. |
| 2. The AE-301 tank with pump.             |
| 3. The AA-351 or AA-352 power box.        |

## III Installation

1. Before you install the pump tank, you can temporarily remove the water tank so that you can install the pole-mount brackets.

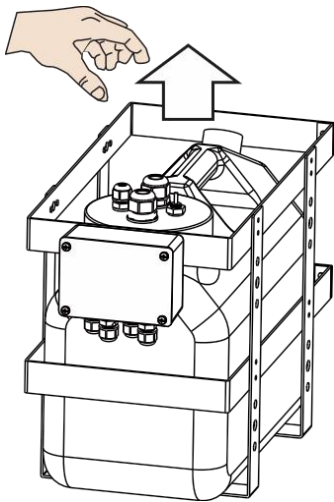

**2.** Assemble the pump head, water level sensor to the tank lid.

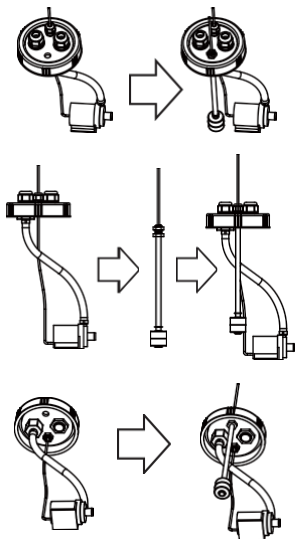

**3.** Install the controller unit box to the pump bracket. Note that you do not need to install the PCB board.

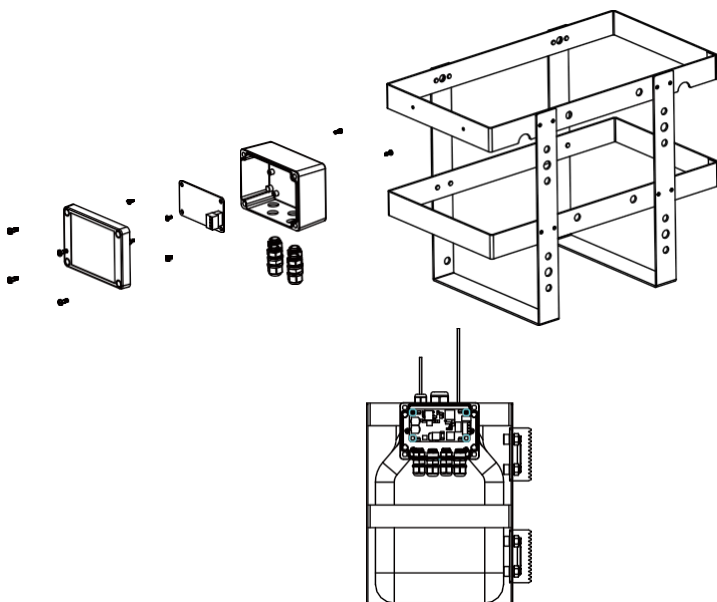

4. You can install the washer unit to a wall or using the pole-mount. If pole-mount is preferred, secure the pole-mount brackets to the metal cage.

Pole-mount bracket

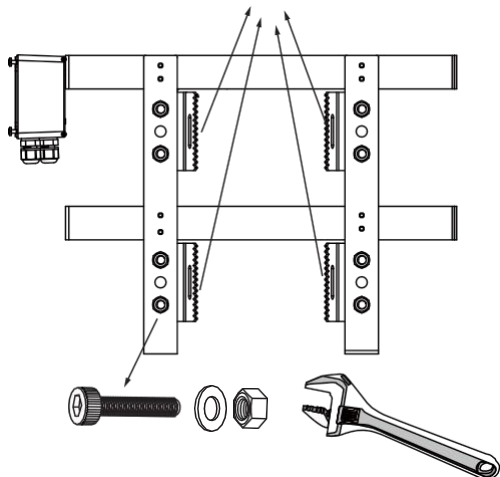

5. Pass the stainless steel straps through the bracket and around the pole. Tighten the straps using a pincer plier and a flat blade screwdriver.

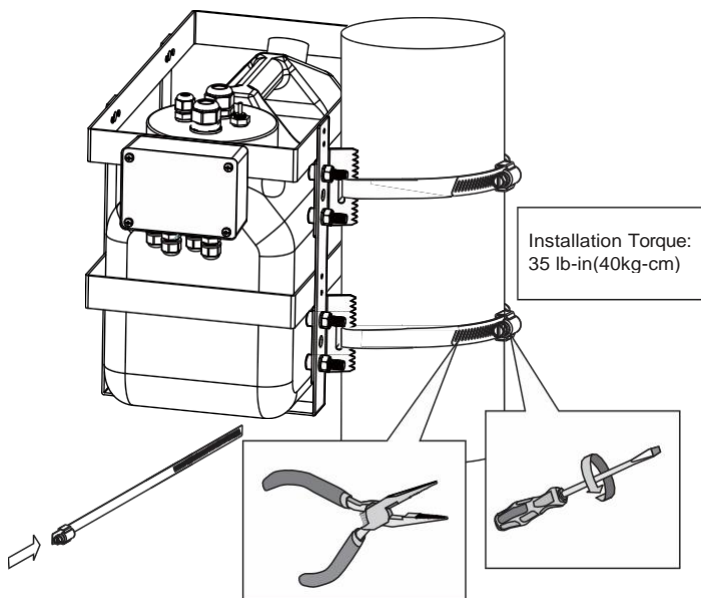

**6.** Install the washer bracket (along with the washer nozzle) to the side of the speed dome using the included screws. The SD9366 is shown in here. Connect the washer silicone pipe to the nozzle. Secure the connection with a cable tie.

The max. pump delivery is 4.5 meters.

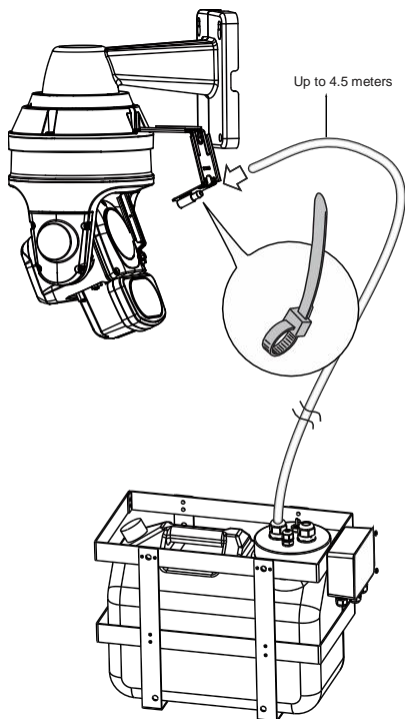

Speed Dome with washer kit.

AE housing with washer kit.

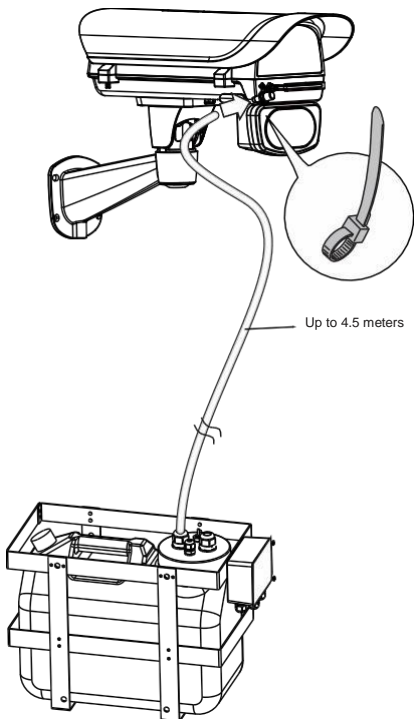

# Water Tank Connection with Speed Dome:

7. Open the waterproof panel box cover. Connect the DI/DO control wires from the speed dome camera to the control panel as illustrated below. Additional length of wires are user-supplied.

The pump tank can be powered by 24V AC power source from the AA-351 and AA-352 power box.

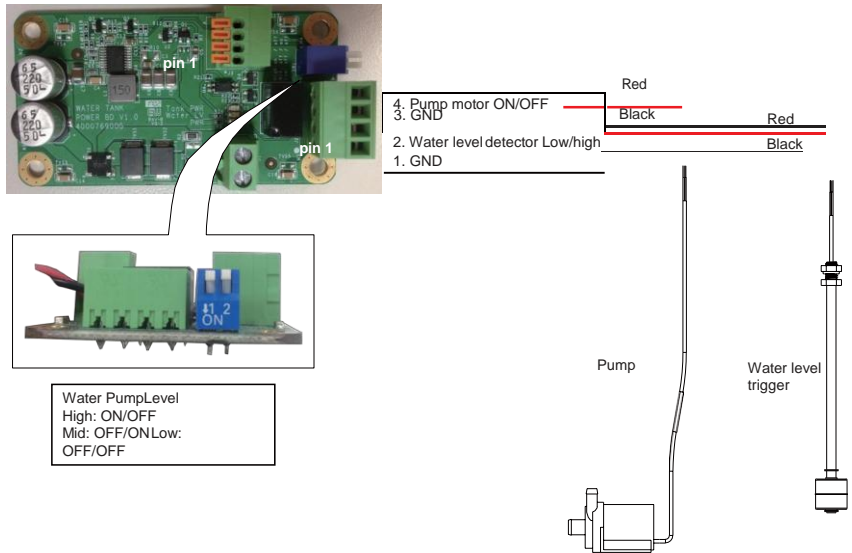
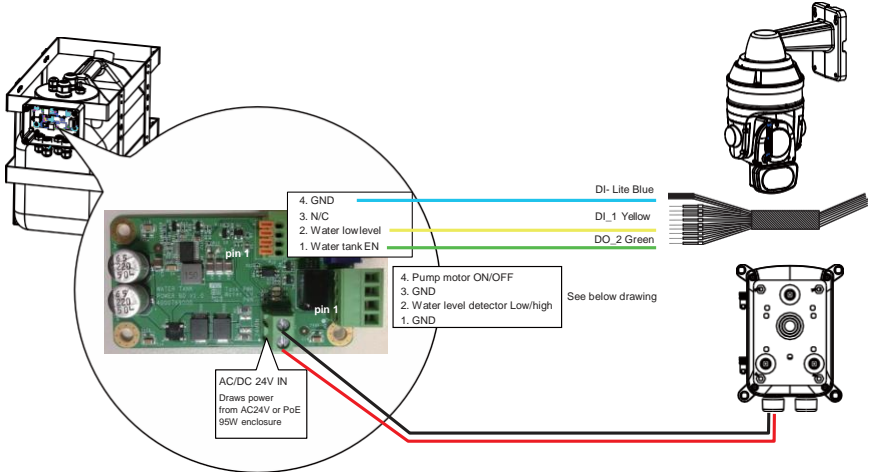

8. Make sure all wirings are waterproof. Lock the cable glands properly. When wiring is done, install the panel cover.

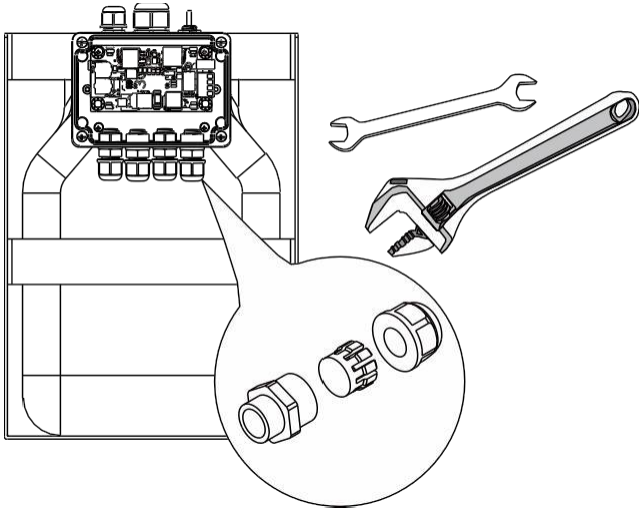

# Water Tank Connection with Enclosure:

There are two ways to control water tank with camera, DI/DO and RS485.

A sample connection diagram consisting of an enclosure and the IP816A camera is shown below. Please refer to your camera's documentation if your camera comes with different pinouts. Below figure is a diagram for controlling water tank via RS485 command from camera UI.

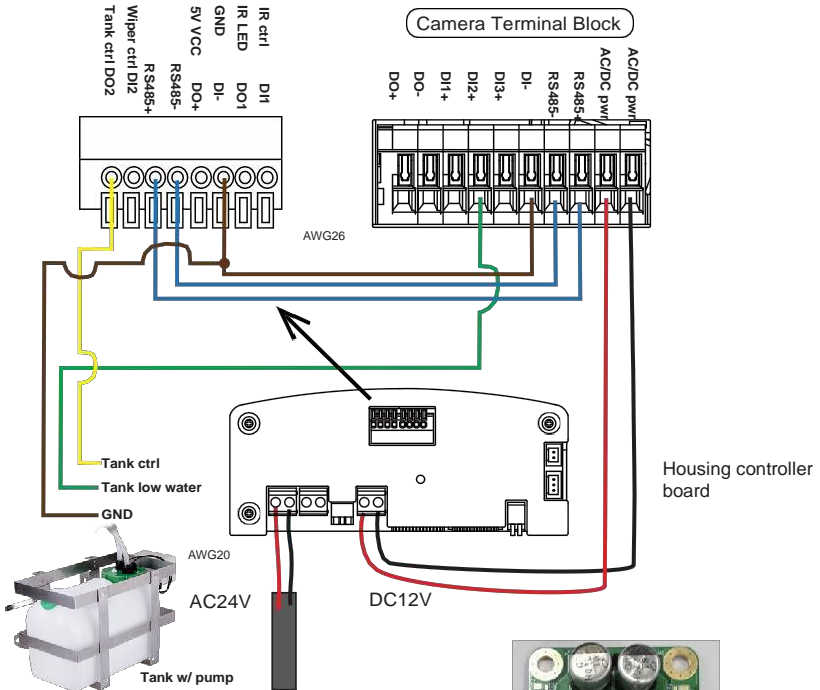

See drawing on the right for the washer kit control board pinouts.

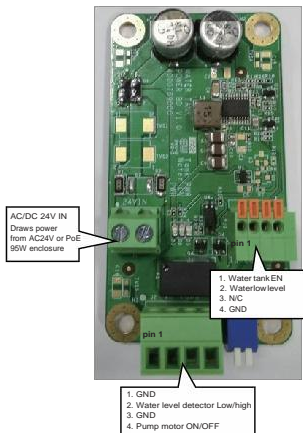



Below is a diagram for controlling water tank via DIDO. The wiper can be started by manually triggering the Digital Output from the camera user interface.

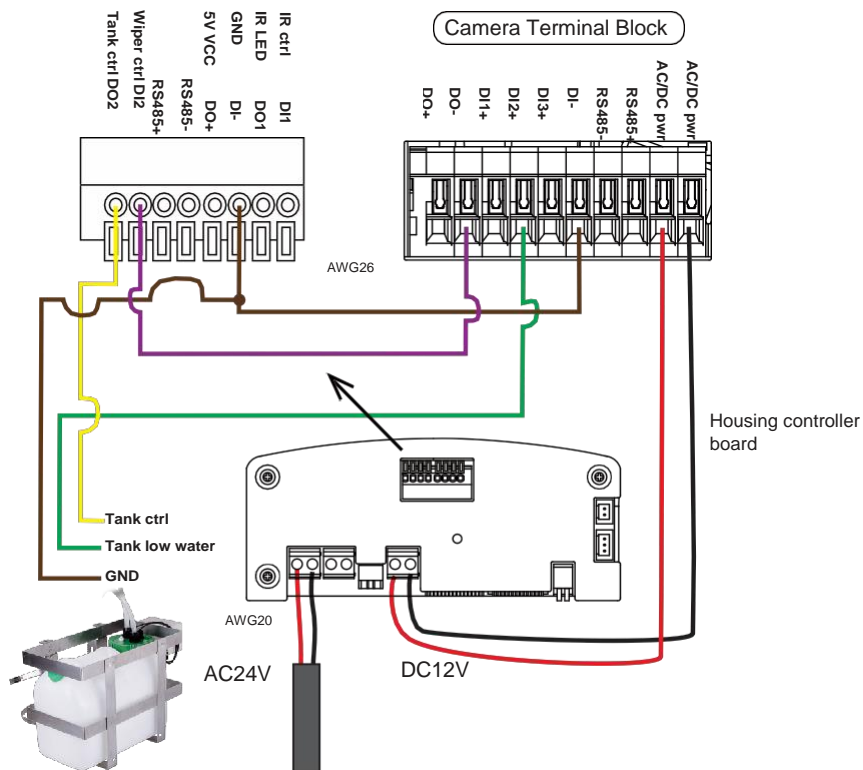

9. Fill the tank with water. The system is ready to be powered.

10. Open a web console with the camera. Enter Configuration > PTZ settings. Select "Washer" in the the Washer options menu.

Version: 0100

11. To start a washing action, click on the **ON** button of the Washer control. The following actions will ensue:

1. The speed dome lens will turn to the preset position for washing.
2. The DO2 connection will trigger the tank pump to spray water.
3. The camera wiper will start.

**NOTE:** If you select the Wiper mode, the washer water spraying will not function.

**12.** Any of the DI pins can be used for water low level detection. The signal is normally High. When the tank water drops below the level, the corresponding DI input will trigger (Active Low). Make sure the firmware configuration is correct. Check Configuration > Applications > DI and DO.

The screenshot displays the VIVOTEK web interface for configuring digital inputs and outputs. The page title is "Applications > DI and DO". The left sidebar contains a navigation menu with the following items: System, Media, Network, Security, PTZ, Event, Applications (highlighted), Motion detection, DI and DO (highlighted), Audio detection, Package management, Recording, and Local storage. The main content area is titled "Applications > DI and DO" and contains the following configuration sections:

- Digital input 1:** Normal status:  High  Low; Current status: **High**
- Digital input 2:** Normal status:  High  Low; Current status: **High**
- Digital input 3:** Normal status:  High  Low; Current status: **High**
- Digital input 4:** Normal status:  High  Low; Current status: **High**
- Digital output 1:** Normal status:  Open  Grounded; Current status: **Open**
- Digital output 2:** Normal status:  Open  Grounded

The other mounting options are illustrated below. They include AM-314, AM-315, and AM-414.

